

Increasing the drawing height of conical square cups using anti-lock braking system (ABS)[†]

Muammer Gavas*

Department of Mechanical Education, Technical Education Faculty, Dumlupınar University, Simav-Kütahya, Turkey

(Manuscript received November 14, 2008; Revised June 4, 2009; Accepted July 21, 2009)

Abstract

This paper deals with increasing the drawing height of metal conical square cups with anti-lock braking system (ABS). A novel technique enabling higher drawing height than that achieved in the conventional deep drawing process is introduced, and the principle of the process is explained in this paper. Results of experiments conducted using aluminum alloyed Al-1050 blanks of thickness of 1 mm to draw conical square cups are reported here. Measured drawing load, drawing height and thickness distributions were compared with those obtained from the conventional method. The experimental results showed that higher drawing height of the cup can be achieved by the use of ABS.

Keywords: Anti-lock braking system; Drawing height; Deep drawing; Blank holder

1. Introduction

The deep drawing process, which is used widely in industry, produces cups at various heights. In conventional deep drawing, the process parameters are selected carefully to enable the drawing of good quality cups at the maximum possible drawing heights. Improvements in the tooling, proper lubrication of the die and optimum design of the punch and die radii by the use of finite element analysis, may increase the drawing height slightly [1]. In these processes, some shallow components can be obtained only with a single drawing operation. However, due to some limitations especially limiting drawing ratio (LDR), which is the ratio of initial side length of a blank that can be drawn without failure to the punch side length for square shaped cups, highly deep or complex shaped cups cannot be obtained with a single drawing operation; they require multi-redrawing or other added operations. This means that forming processes require

several operations until the final shape is obtained. In other words, these limitations prevent to reach the desired drawing height. Multi-redrawing processes and other added operations increase manufacturing costs and consume more time to obtain the desired shape of the cup. In addition, these processes affect the mechanical properties of the material.

To overcome these limitations of the process and to obtain deeper and good quality cups, new variations have been introduced over the years, notable in this category being hydro forming, hydro mechanical forming, counter pressure deep drawing [1], and tool temperature control in deep drawing [2].

Bolt et al. [3] conducted warm drawing tests for both box-shaped and conical rectangular products. The results show that forming at elevated temperature can yield a significant increase in product height, especially for conical products. The maximum height of a box-shaped deep drawn product can be increased by 25% when a die temperature of 175 °C is used. The maximum height of a conical stretched-drawn product can be increased by 65% when a die temperature of 250 °C is used. Wan et al. [4] used a theoretical approach and experimental results to determine

[†] This paper was recommended for publication in revised form by Associate Editor Youngseog Lee

*Corresponding author. Tel.: +90 274 5137917, Fax.: +90 274 5137914

E-mail address: mgavas@dumlupinar.edu.tr

© KSME & Springer 2009

the fracture criteria and the limiting drawing ratio (LDR) for conventional deep drawing of conical cups. They stated that limit stress of cylindrical cups is slightly lower than that of conical cups. Rolla [4] stated that higher deep drawing ratio and hence higher depths of draw can be achieved with hydro mechanical deep drawing. Hydro mechanical deep drawing is thus a cost-effective solution to manufacture metal cups with high drawing ratios in a single drawing stroke. Koyama and Manabe [5] proposed a virtual processing algorithm for the intelligent stamping process. Through the implementation of the system, it was confirmed that all the process phases are virtually performed in order, and finally, cup height improvement was accomplished. Each of these above-mentioned processes have distinguishing features and limitations. In spite of all the good results of these novel processes, there are still some restrictions that affect having deeper drawing height in a single operation.

In this study, the ABS was used for conical square cup drawing to increase drawing height. For this, the actual conical square cup drawings were conducted using Al-1050 aluminum sheet and experimental data were obtained. Drawing heights, drawing loads, wall thicknesses and other parameters obtained from conventional method and ABS were compared.

2. Deformation analysis

Conical cup drawing is more difficult than cylindrical cup drawing [6]. In this operation, as shown in Fig. 1, the side wall is unsupported, which is the major difference from cylindrical cups [7]. The box-shaped products are made by deep drawing, the conical products by a combination of deep drawing and stretching. Especially, the latter is often encountered in stamping of automotive panels [3].

At the beginning of the drawing process, contact region of the die radius and punch radius is minimum while semi-cone angle γ is maximum. In contrast to this case, at the end of the drawing process however, both contact regions of the two radii are the maximum while the semi-cone angle γ is minimum (Fig. 1).

The deep drawing operation is successful as long as $F_{p, \max} < F_{Br, \text{conv}}$, where $F_{p, \max}$ is the maximum punch force and $F_{Br, \text{conv}}$ is fracture strength of the material. Details of these formulas and theoretical analysis of deep drawing process can be found in Ref. [4].

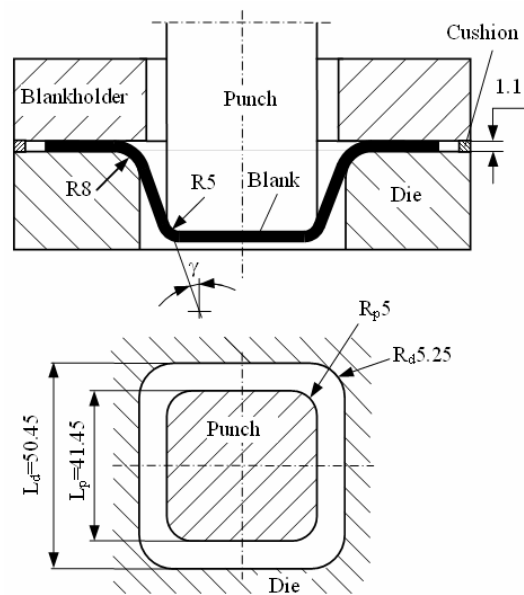

Fig. 1. Punch and die geometry used in the experiments, (mm).

3. Design and working of the anti-lock braking system (ABS)

An understanding of the design and working of the ABS system is important; because of this, the full details of the system were explained in this section. A deep drawing system with ABS mainly consists of conventional deep drawing apparatus incorporating ABS devices, on which mechanically applied consecutive braking/hammering works on the blank. As it is seen in Figs. 2 and 3, a 1 kW AC motor with three-phase and a speed of 1611 rpm has been mounted on the 80 ton hydraulic press under the die set. The circular motion taken from the motor is transmitted to the eccentric axle mounted below the press table, by using two 'V' belts, then the power is transmitted using two compression rods, which are mounted to the two ends of the eccentric axle at the vertical position. So, the motion is transmitted linearly to the bolster plate. After the required adjustments have been done, the AC motor is turned on. The circular motion taken from the motor is converted into linear motion at the compression rods. This linear motion compresses the blank by the bolster plate and blank holder, respectively. At this time, the blank is exposed to anti-lock braking/hammering. This system is similar to ABS used on automobiles hydraulically and mechanically. Therefore, the sys-

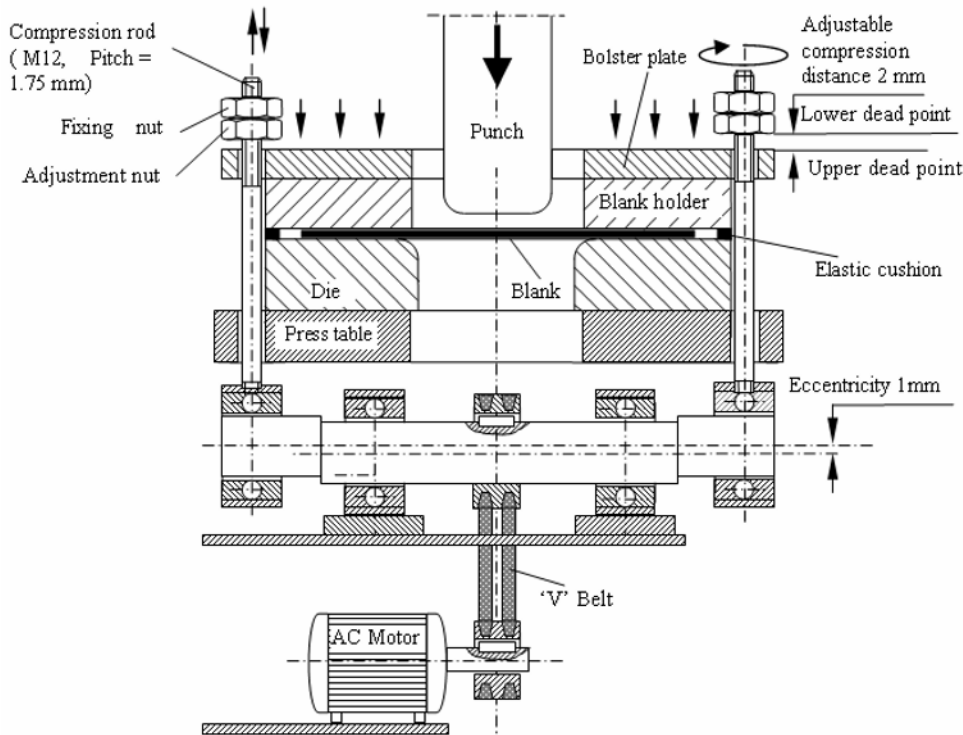

Fig. 2. Experimental setup of newly developed deep drawing machine with ABS.

tem was called “Deep drawing with ABS” by the author [8]. In their study different blank geometry, punch velocity, blank material and die dimensions have been used to produce square cup when compared to this study. The ABS, which works independently from the punch movement, can be conducted in any stage of the deep drawing process. Due to single vertical directional compression movement, which corresponds to the direction of the punch axis, tool position and especially placing position of the blank are not affected adversely during drawing operations. This system does not constitute any additional friction forces in the horizontal direction between the die, blank and blank holder. Therefore, excessive heat does not occur during deep drawing as mentioned in Ref. [9]. Deep drawing with ABS does not require excessive expense and apparatus. Therefore, it can be adapted easily to every drawing machine.

3.1 Material and equipment

In this study, the capability of the newly developed deep drawing system with ABS was tested. During the experiments maximum drawing height, wall

thickness distributions and drawing loads were examined. The experiments were carried out on an 80 ton hydraulic press. Commercially available Al-1050 aluminum sheet with a thickness of 1.00 mm was used as the blank material. The mechanical properties of the aluminum sheet are shown in Table 1. The blanks were cut from aluminum sheet and edges of the blanks manufactured precisely.

Considering preliminary experiments, in which the round shaped blanks with diameter of less than 100 mm and the square blanks less than 90 mm edged were drawn without failure due to small LDR, constant dimensioned round shaped blanks ($\varnothing 110$ mm) and square blanks ($\square 100$ mm) were used in the experiments. The LDR for the square and circular blanks were constant as well. Therefore, drawing height (punch stroke) was progressively increased by 1 mm starting from drawing height of 10 mm. In the experiments, instead of using a blank holder force (BHF), a blank holder gap (BHG) was used which is defined as the distance between the lower surface of blank holder and upper surface of die. This gap (BHG) also, determines the maximum wrinkling height [10]. For the conventional drawing tests, this

Table 1. Mechanical properties of Al-1050 aluminum sheet [2].

Specimen angle to rolling direction	Tensile properties				
	Yield stress MPa	Tensile stress MPa	Uniform strain		
0°	114.93	125.91	0.020		
45°	123.26	132.97	0.019		
90°	126.99	135.72	0.017		
Formability parameters					
	k	n	r	rm	Δr
0°	16.8	0.065	0.67		
45°	17.5	0.060	0.45	0.58	0.25
90°	17.6	0.056	0.73		

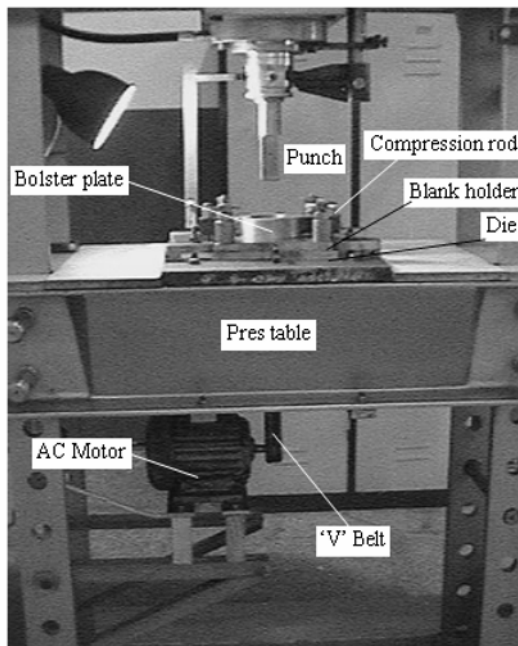

Fig. 3. Picture of experimental setup of newly developed deep drawing machine with ABS.

gap was chosen as 1.1 mm which is the 110% of the material thickness, which is ideal for single press action and provided by the metal cushion. Since the maximum BHG is constant, blank holder cannot have more than a 1.1 mm gap during drawing; therefore, the blank does not wrinkle significantly. For the tests with ABS, the maximum value for this gap can be 2.709 mm (1 mm blank thickness + 1.709 mm compression distance) during wrinkling.

After adjusting this gap, four elastic cushions with

a thickness of 1.1 mm were located on the corners of the die, which provided balanced movement of the blank holder to the blank from every section during compression. Since the maximum BHG is constant, blank holder gap cannot be more than 2.709 mm during drawing. During compression, however, elastic cushions allow the dimension of this gap to be reduced till a 1. mm which is equal blank thickness. This means that on one hand the BHG is used to control metal flow, and on the other hand, during compression, ABS is used as a BHF to improve metal flow. BHG and partially BHF are conducted together in the drawing process.

3.2 Adjustment of compression distance

For the adjustment of the compression distance, the eccentric axle is brought to the lower dead point and the adjustment nut is tightened until it touches to the bolster plate (Fig. 4). Later, the eccentric axle is brought to the upper dead point being rotated a half revolution. In this case, the distance between bolster plate and adjustment nut is 2 mm (Fig. 5). Following that, the adjustment nut is rotated 1/6th revolution. At this time, the adjustment nut moves vertically 0.291 mm below (M12 bolt pitch is 1.75 mm and the movement is $1.75/6 = 0.291$ mm). Finally, fixing nut is fixed. In this case, when the vertical displacement of the compression rod is 2 mm at one cycle initially, it becomes 1.709 mm ($2 - 0.291$ mm) after rotating the adjustment nut 1/6 cycle (Fig. 6). For a complete one rotation of the axle, the taken eccentric distance is to be 2 mm. However, this distance is restricted with 1.709 mm. In this case, the distance 0.291 mm is used to brake the blank with anti-lock. At the same time, this action conducts slight hammering effect to the blank. The movement of one cycle of the axle is conducted in 0.037 s. This compression action does not hold the blank; it holds and leaves the blank continuously. This phenomenon is carried out 1611 times per minute. During this time, some portion of the compression distance is absorbed by mechanisms as elastic deformation. During the deep drawing process, when the punch force forms the blank in the die cavity with a constant speed, at the same time, the rest of the blank (undrawn/flange of the part) is exposed to anti-lock braking consecutively between die and blank holder. This process occurs only at the drawn cup walls, but the bottom of the cup, which is under the punch, is not affected from this action.

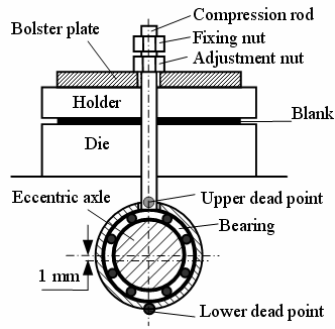

Fig. 4. Initial position of adjustment distance.

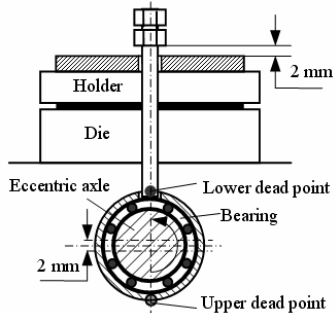

Fig. 5. Adjustment of maximum motion distance.

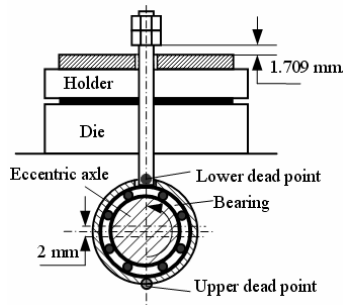

Fig. 6. Adjustment of motion distance used in the experiment.

3.3 Experiments

Square cup drawing tests were performed as a means of determining the maximum drawing height for a given tooling geometry. The dimensions of the deep drawing tooling are shown in Fig. 1. Because of the softness of the blank material, die materials were chosen from middle carbon steel. In this study, a 2 mm/s constant punch velocity was used for all experiments. Upper surface and cavity of the die, lower and upper surfaces of the blanks and, lower surface of the blank holder were lubricated with mobile oil 30.

Preliminary experiments show that punch strokes of less than 10 mm are drawn without failure. Therefore, punch strokes are progressively increased 1 mm starting from the punch stroke of 10 mm. When the failure of the blank occurs, experiments proceed with the punch stroke increasing and decreasing by 1 mm to ascertain the maximum stroke of the punch without failure in conical cup drawing. Each test was repeated several times before and after the cup failure to ensure that there was no coincidence in the operations and, maximum drawing height was determined when there was no drawing failure. Tests were performed in two series, the first with conventional method and the second is with ABS.

3.3.1 Conventional deep drawing tests

To obtain the maximum drawing height at which deep drawing can be attained successfully, deep drawing tests were performed. In these tests circular and square shaped blanks with constant blank size were used for conventional deep drawing and deep drawing with ABS tests.

For square-shaped blanks having a 100 mm edge, tests up to the drawing height of 17 mm ($LDR = 100/41.45=2.41$) were successful. For further increasing of the punch stroke, it caused fracture at one or two punch shoulder parts; therefore, the maximum drawing height can be found to be around 18 mm for square blanks. For round-shaped blanks having diameter of 110 mm, tests up to the drawing height of 12 mm ($LDR = 110/41.45=2.65$) were successful. Further increasing of the punch stroke caused fracture at one or two punch shoulder parts; therefore, the maximum drawing height can be found to be around 12 mm for round-shaped blanks.

3.3.2 Deep drawing tests with ABS

In these experiments, conventional deep drawing processes were carried out incorporated with ABS. Deep drawing tests up to the drawing height of 30 mm ($LDR = 100/41.45=2.41$) for square blanks were successful. Further increasing of the punch stroke caused fracture at one or two punch shoulder parts; therefore, the maximum drawing height can be found to be around 30 mm for square blanks. For round-shaped blanks having diameter of 110 mm, tests up to the drawing height of 17 mm ($LDR = 110/41.45=2.65$) were successful. Further increasing of the punch stroke caused fracture at one or two punch shoulder parts; therefore, the maximum draw-

ing height can be found to be around 17 mm for round shaped blanks.

4. Experimental results and discussion

4.1 Comparison of drawing height

The exact cup height was determined when adjacent tests were continuously drawn. Likewise, the punch stroke of the next tests was 1 mm bigger than the last successfully drawn punch stroke suffering fracture. For instance, blanks were drawn at punch stroke $s_p=11$ mm and 12 mm; however, fracture occurred at punch stroke $s_p=13$ and 14 mm. Hence, punch stroke $s_p=12$ mm was admitted as the maximum drawing height. For conventional deep drawing: blank diameter of 110 mm and cup height of 13 mm, for deep drawing with ABS; blank diameter of 110 mm and cup height of 18 mm were successful. Hence, drawing height was increased from 13 mm to 18 mm by ABS for the circular blank. For conventional deep drawing: blank edge of 100 mm and cup height of 18 mm, for deep drawing with ABS; blank edge of 100 mm and cup height of 31 mm were successful. Hence, drawing height was increased from 18 to 31 mm by ABS for the square blank. Due to the limitation of the blank size and LDR, deeper cups could not be obtained.

Figs. 7 and 8 show photographs of deep drawn cups at given process conditions. The experimental results show that higher drawing height can be obtained by the use of ABS. Fig. 9 shows the comparison of cup heights obtained by the two methods, conventional and with ABS. The cup height with ABS increased by 5 mm more than the conventional one for circular blank and increased by 13 mm more than the conventional one for square blank.

4.2 Comparison of the drawing loads

Figs. 10 and 11 show the complete relationship of punch load versus punch travel over the entire forming process for the circular and square blanks with conventional and ABS methods. The trend of the entire process and of the maximum load correlated with each other both with conventional and ABS. In Figs. 10 and 11, the slight decrease of the maximum load for ABS is due to not only the effect of the reduction in friction but also the Blaha effect (reduction in deformation resistance at the flange part) [9], and wrinkling preventive effect of the ABS.

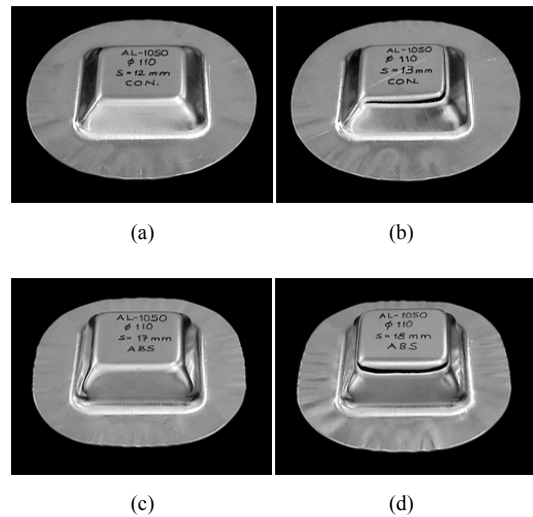

Fig. 7. Height of cups: (a) drawn with conventional method, blank diameter 110 mm, $s_p=12$ mm, (b) drawn with conventional method, blank diameter 110 mm, $s_p=13$ mm, (c) drawn with ABS, blank diameter 110 mm, $s_p=17$ mm, (d) drawn with ABS, blank diameter 110 mm, $s_p=18$ mm.

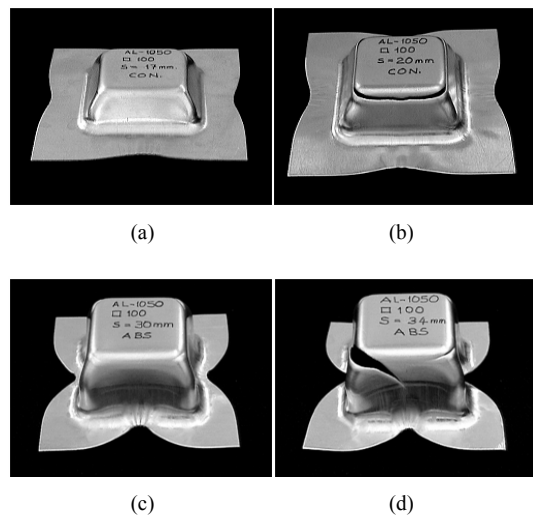

Fig. 8. Height of cups: (a) drawn with conventional method, square blank \square 100 mm, $s_p=17$ mm, (b) drawn with conventional method, square blank \square 100 mm, $s_p=20$ mm, (c) drawn with ABS, square blank \square 100 mm, $s_p=30$ mm, (d) drawn with ABS, square blank \square 100 mm, $s_p=34$ mm.

During drawing, the material is forced wrinkling and thickening; these increase friction and require more force. However, the ABS slightly prevents wrinkling and material is drawn more easily.

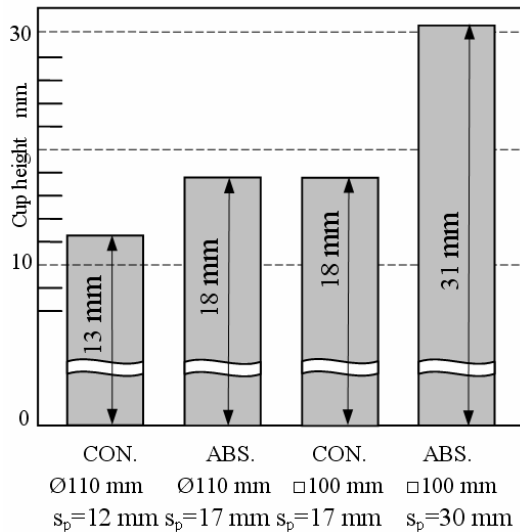

Fig. 9. Comparison of cup heights, (cup height = punch stroke + blank thickness).

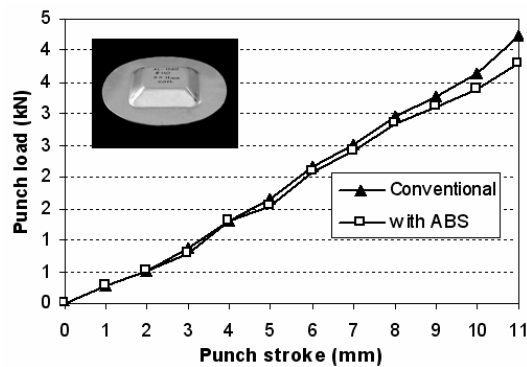

Fig. 10. Comparison of punch loads and punch stroke for circular blank. (Diameter of blank 110 mm, punch stroke 11 mm).

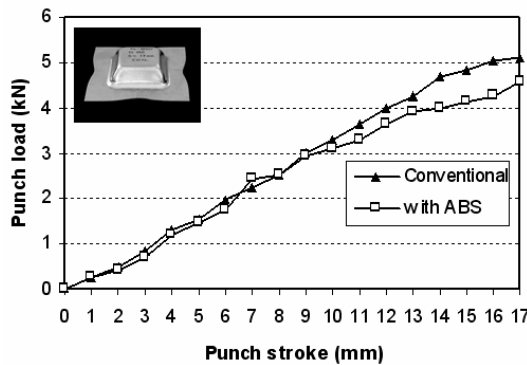

Fig. 11. Comparison of punch loads and punch stroke for square blank. (Edge of square blank 100 mm, punch stroke 17 mm).

4.3 Comparison of the cup wall thickness

All of the drawn cups stated in Figs. 12 and 13 were cut off along the OA and OB axes. During cutting off, measuring lines and form of the cups were protected from deformation and being ragged. Then, a micrometer with a cone-point attachment was used to measure the thickness of the work pieces. Fig. 12 presents a comparison of the sheet-thickness distribution obtained from conventional and with ABS methods over the developed lengths of the generatrix for circular blanks. The distributions of the thickness involve five parts: A, B, C, D and E. The region A represents the bottom of the cup, the region B represents the punch arc portion of the cup, the region C represents the inclined-wall portion of the cup, the region D represents the die arc portion of the cup and the region E represents flange of the cup. Generally, the region A, which is under the punch, remained unchanged. The first thinning occurred in region B

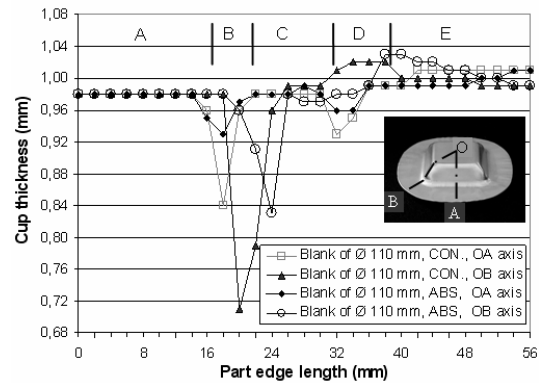

Fig. 12. Comparison of the thickness distributions along the OA and OB axes for circular blank.

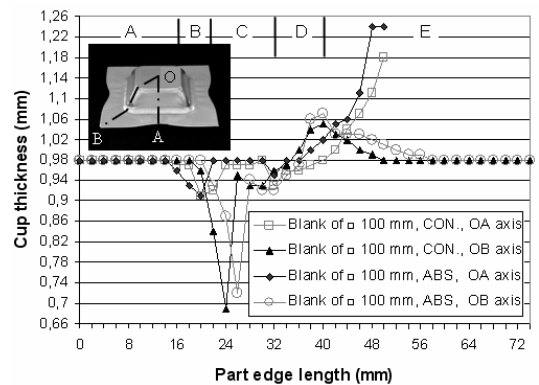

Fig. 13. Comparison of the thickness distributions along the OA and OB axes for square blank.

for two cups. This is attributed to the maximum tensile force and stress concentration that occurred at the punch arc point. There were no significant changes at the inclined walls. The second thinning was observed in region D due to tensile forces occurring in the flange of the cup and round shaped blank that causes fairly ear and increases tensile force. The thickness of the flange slightly increased due to decreasing of the blank diameter, circumferential compressing and low drawing height.

For the square blanks, however (Fig. 13), there are clearly more differences in cup wall thickness especially in line OA, i.e., in the middle of the flange. Here, during drawing, on one hand metal flows radially towards die cavity, but on the other hand metal flows from corner to the middle of the edge. Because of this, wrinkling occurs in the middle of the part edge. This causes increasing in thickness slightly. In contrast, in the corner of the flange, there is no metal flow and wrinkling. Therefore, the thickness of the corner of the flange part remained unchanged.

Generally, there is no significant difference in thickness distributions between two cups drawn with conventional and with ABS. But, as shown in Ref. 8, it can be said that during drawing, the ABS method slightly prevents wrinkling and eases metal flow. Consequently, thinning in the arc portion of the cups is slightly fewer less than in the conventional method.

In conical square cup drawing, in contrast to cylindrical and box-shaped square cup drawing, “bulging” occurs on the corner of the cup as shown in Fig. 14. The periodical wrinkling in the cup wall is preceded by an outward “bulging.” Because of the cup-wall curvature, the circumferential compressive stress will produce a small force pointing outwards, thus causing bulging. This effect is more pronounced in small cups with tighter curvature than in large ones. Bending of

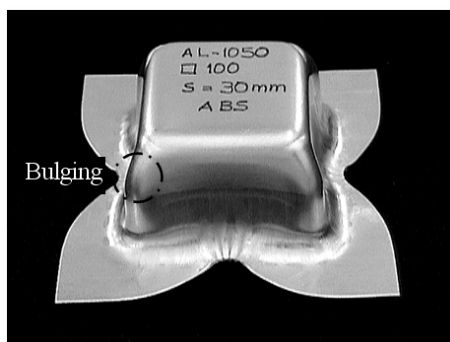

Fig. 14. Bulging occurring in conical square cup drawing.

blank over die-profile radius and its subsequent straightening in the die orifice also contributes to the bulge formation [10].

5. Conclusions

Deep drawing of conical square cups with ABS, based on braking of the blank by the ABS with the interval of very short time, is proven to be feasible. The new method brings about the possibility of improving the deep drawability of Al-1050 aluminum sheet and it increases drawing height. The ABS, working independently from the punch movement, can be conducted in any stage of the deep drawing process. During deep drawing, due to the movement of the blank holder up and down, forced lubrication occurred which facilitated the sliding of the blank between die and blank holder. The thickness distribution is not affected adversely by the ABS. Compared to other drawing methods including vibration, heat does not occur in this method. In spite of advantages, this method has some disadvantages as well. Single directional strong vibration occurs on the press and tools, which can cause loosening of the clamping devices and can be inconvenient for sensitive measuring instruments.

References

- [1] S. Thiruvarduchelvan, H. B. Wang and G. Seet, Hydraulic pressure enhancement of the deep-drawing process to yield deeper cups, *Journal of Materials Processing Technology*, 82 (1998) 156-164.
- [2] Y. H. Moon, Y. K. Kang, J. V. Park and S. R. Gong, Tool temperature control to increase the deep drawability of aluminum 1050 sheet, *International Journal of Machine Tools & Manufacture*, 41 (2001) 1283-1294.
- [3] P. J. Bolt, N. A. P. M. Lamboo and P. J. C. M. Rozier, Feasibility of warm drawing of aluminium products, *Journal of Materials Processing Technology*, 115 (2001) 118-121.
- [4] T. Khandeparkar and M. Liewald, Hydro mechanical deep drawing of cups with stepped geometries, *Journal of Materials Processing Technology*, 202 (2008) 246-254.
- [5] H. Koyama and K. Manabe, Virtual processing in intelligent BHF control deep drawing, *Journal of Materials Processing Technology*, 143-144 (2003)

- 261-265.
- [6] M. Wan, Y. Y. Yang and S. B. Li, Determination of the limiting drawing coefficient in the deep drawing of conical cups, *Journal of Materials Processing Technology*, 114 (2001) 114-117.
- [7] M. Wan, Y. Y. Yang and S. B. Li, Determination of fracture criteria during the deep drawing of conical cups, *Journal of Materials Processing Technology*, 114 (2001) 109-113.
- [8] M. Gavas and M. İzçiler, Deep drawing with anti-lock braking system (ABS), *Mechanism and Machine Theory*, 41 (2006) 1467-1476.
- [9] T. Jimma, Y. Kasuga, N. Iwaki, O. Miyazawa, E. Mori, K. Ito and H. Hatano, An application of ultrasonic vibration to the deep drawing process, *Journal of Materials Processing Technology*, 80-81 (1998) 406-412.
- [10] J. Havranek, The effect of mechanical properties of sheet steels on the wrinkling behaviour during

deep drawing of conical shells, *Journal of Mechanical working Technology*, 1 (1977) 115-129.



Muammer Gavas received his B. S. in Mechanical Education from Gazi University, Turkey, in 1979. He then received his M.S. degree from Dumlupınar University, in 1995 and Ph.D. degree from Marmara University in 1998. Dr. Gavas is currently an Associate Professor at the Simav Technical Education Faculty at Dumlupınar University in Kütahya, Turkey. He serves as a chairman of the Mechanical Education department. His research interests include deep drawing, explosive forming, and chip removal processes.